

Composite dry sliding bushings, Composite dry sliding flanged bushings

Principal dimensions					Basic load ratings				Mass	Designation
d	D	D <sub>1</sub>	B	B <sub>1</sub>	radial dynamic C	static C <sub>0</sub>	axial dynamic Ca	static C <sub>0</sub>		
mm					kN				kg	-
<b>15</b>	17	23	12	1	12	37,5	10,4	32,5	0,0062	PCMF 151712 E

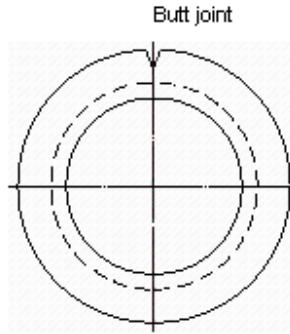
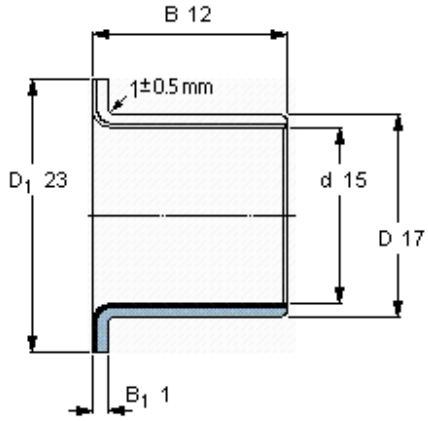

**Specific load factor**  
**Material constant**

K 80  
K<sub>M</sub> 480